

INDUSTRIAL TECHNOLOGY ADVANCES

Wireless network technologies toward 5G

DAI KIMURA¹, HIROYUKI SEKI², TOKURO KUBO² AND TOMOHIKO TANIGUCHI¹

Fifth generation mobile communications (5G) are expected to accommodate rapidly increasing mobile traffic aiming at the realization of a “Hyper Connected World” in which all people and surrounding things are connected and information is exchanged between them, and to play the role of a basis of the Internet of everything. A lot of research projects have started focusing on the research of 5G since around 2013, and some agreements are being formed about the vision and the candidate technologies of 5G. The 5G wireless network is expected to become a “Heterogeneous Network” where new wireless access technologies incompatible with 4G and the wireless access technologies for unlicensed band are incorporated with the enhanced technology of 4G (e.g. IMT-advanced). This paper introduces the vision and technology trends of 5G, shows key directions of the research and development of 5G in the future, and introduces some of our studies on 5G.

Keywords: Fifth generation mobile communications, Internet of everything, Heterogeneous network, Multi-RAT, Energy efficiency

Received 30 March 2015; Revised 27 August 2015

I. INTRODUCTION

A rapid increase of mobile traffic by more than 60% per year is expected due to the recent spread of smart phones and tablet terminals [1]. Moreover, it is predicted that the number of terminals connected with the Internet will reach 50 billion in 2020 [2]. The fifth generation mobile communications (5G) will be a new wireless telecommunications standard with which commercial services are expected to start being compliant from 2020s in order to accommodate such increasing traffic.

The vision, candidate techniques, required performance, and other aspects of 5G have been actively investigated in many research projects such as 5GIC (<http://www.surrey.ac.uk/5gic/>), METIS (<https://www.metis2020.com/>), and 5G-PPP (<http://5g-ppp.eu/>) in Europe, FUTURE MOBILE COMMUNICATION FORUM (<http://www.future-forum.org/en/>) in China, and 5G Forum (<http://www.5gforum.org/eng/main/index.php>) in South Korea. Dresden Institute of Technology focuses on the reduction of communication delay to accelerate research of the Tactile Internet [3]. 5GNOW proposes new radio access interfaces for 5G (<http://www.5gnow.eu/>). A large-scale measurement campaign of the millimeter-wave propagation is being conducted in New York University and Texas University [4]. In Japan, 2020 and Beyond AdHoc (20BAH) affiliated

with ARIB released a white paper about 5G [5], and the fifth generation mobile communications promotion forum (5GMF) of industry–university–government cooperation started in September 2014 (http://5gmf.jp/index_en.html). Thus, the worldwide research on 5G involving a lot of vendors, operators, universities, and other research organizations has become very active, and workshops of 5G are frequently held at many international academic conferences.

From the results of the above research, people in this field are reaching a rough agreement about the vision, candidate techniques, and required performance of 5G. A new recommendation of the “Vision” for IMT for 2020 and beyond has been completed by WP5D in ITU-R, which proposes three usage scenarios (enhanced mobile broadband, ultra-reliable and low-latency communications, and massive machine-type communications) and eight capabilities (peak data rate, user experienced data rate, etc.) for the system and it also mentions timelines toward the deployment of the system [6]. A new report “Future Technology Trends” also has been completed by WP5D [7]. 3GPP has started discussions about technologies that could be standardized in future standards of 5G such as full dimension multi-input multi-output (MIMO), usage of unlicensed band, multi-radio access technology (RAT) coordination, and so forth.

The 5G wireless network is expected to become a heterogeneous wireless network where a RAT using unlicensed bands, a new RAT incompatible with 4G, existing 4G technologies (e.g. IMT-advanced), and enhanced technology of 4G. In other words, 5G is a wireless network that realizes maximum performance using not one RAT, but several different RATs in order to satisfy different requirements in an effective way.

¹Fujitsu Laboratories Ltd., 4-1-1 Kamikodanaka, Nakahara-ku, Kawasaki 211-8588, Japan

²Fujitsu Laboratories Ltd., 3-2-1 Sakado, Takatsu-ku, Kawasaki 213-0012, Japan

Corresponding author:

D. Kimura

Email: dkimura@jp.fujitsu.com

II. REQUIREMENTS AND CANDIDATE TECHNOLOGIES FOR 5G

It is expected that ICT in the 5G era (5G ICT) can realize activity support, knowledge creation, shared experiences, etc. by gathering a large amount of data from the real world, processing it in the virtual world (Cloud), and feeding back to the real world in real time. The 5G wireless network (or simply 5G) will be a fundamental technology that supports 5G ICT, and accelerates the realization of a “Hyper Connected World” [8] in which all people and things around them are connected and communicate with each other (Fig. 1).

5G needs to satisfy some key requirements for its usage scenarios. It needs to accommodate massive traffic (e.g. 1 Tbps/km²) in order to support the rapid increase of traffic as well as ultra-high-speed communication (e.g. 10 Gbps/device) in order to realize a super-high-quality video delivery, virtual reality, augmented reality, etc. Moreover, low-latency (e.g. RTT of 1 ms) and high-reliability communication are needed in order to realize high-quality M2M communication that supports the Tactile Internet, Industrial Internet (<http://www.ge.com/stories/industrial-internet>), etc. In addition, ultra-high-density devices (e.g. 10⁶ devices/km²) such as small, low-cost, and massive sensors also need to be accommodated in order to realize the Internet of everything (IoE). Achieving them for low cost and with low energy will be a big technical challenge for 5G.

Figure 2 shows the limitation of capabilities of 4G and 5G and also shows four technology regions corresponding to those mentioned above. In the figure, the horizontal axis shows user density, and the vertical axis shows the user throughput. Traffic capacity is calculated by multiplying them. Though low-latency and highly reliable

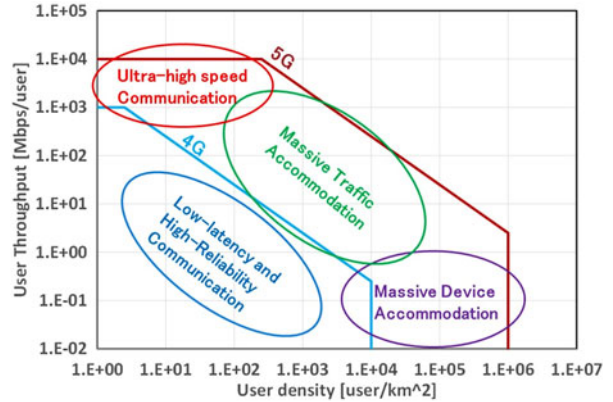

Fig. 2. Technology regions of 5G.

communication can be accommodated by 4G in terms of throughput and user density, there are challenges of delay reduction and reliability improvement that 4G cannot meet. Figure 3 shows a whole picture of 5G technology. C/U-split architecture is an essential technology for 5G. It can satisfy a variety of service demands ensuring the connectivity and mobility by transmitting control plane signals in macro cells, and user plane signals are transmitted in small cells with various RATs. Technology trends in each technology region are outlined in the following sub-sections.

A) Technologies for ultra-high-speed communications

Use of ultra-wide bandwidth greatly contributes to realizing ultra-high-speed communications. In order to find exclusive ultra-wide bandwidth of several GHz, frequency bands are expected to be used that are higher than those ever used for mobile communications, which are

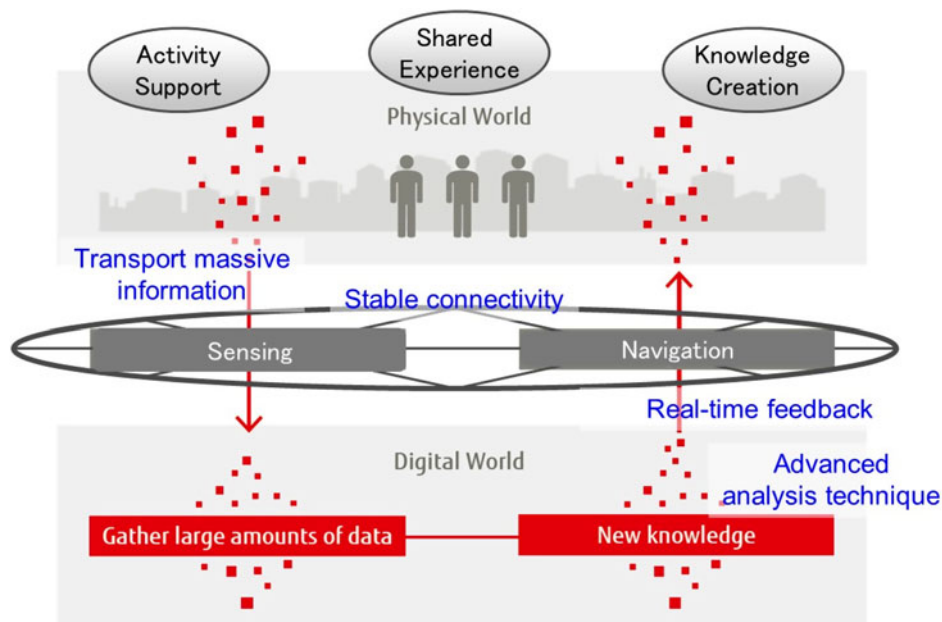

Fig. 1. Roles of 5G ICT.

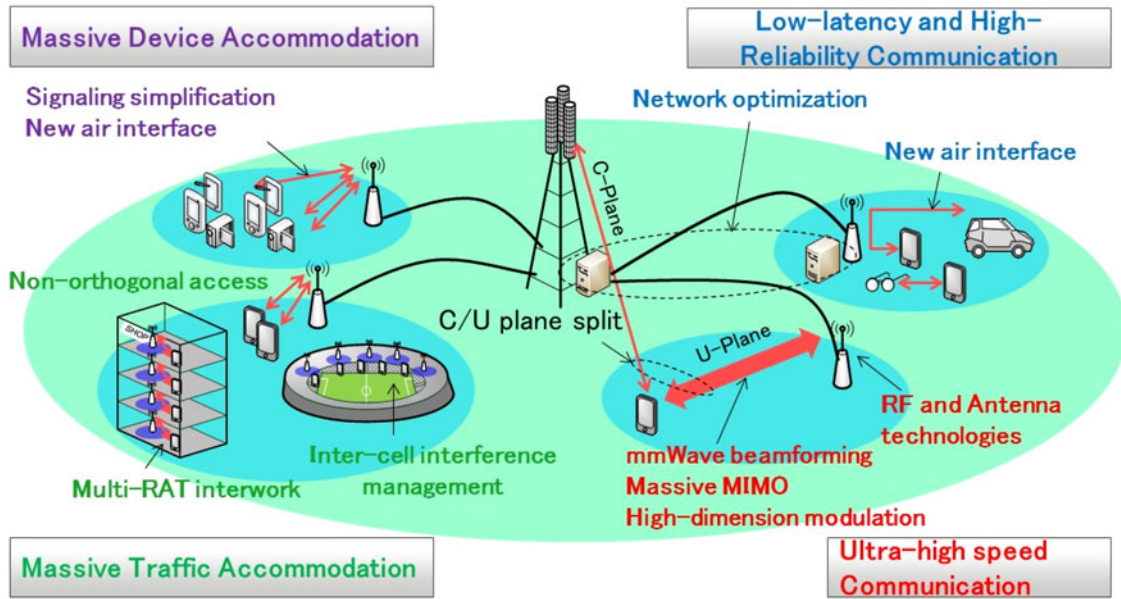

Fig. 3. Whole picture of 5G technologies.

mainly millimeter-wave bands (30–300 GHz). However, millimeter-wave communications have a big problem that the propagation loss and the in-device loss are large, which results in large energy consumption. Massive beamforming with a large number of antenna elements is expected to deal with the large propagation loss, and an integral design of radio frequency integrated circuit (RF-IC) and antennas is expected to combat the large in-device loss [9]. Note that the higher-frequency bands assumed to be used for 5G is so far limited to a range from 6 GHz to about 80 GHz, which is not identical to the range of millimeter-wave frequency (30–300 GHz).

Since uplink traffic is also expected to increase in future, the millimeter-wave communications for uplink is worth considering. To reduce transmission power of mobile stations, user multiplexing in frequency domain may be effective. The base station needs multiple beams to receive the uplink signal at the same time slot in this scenario, which may increase the cost and power consumption of base stations (see Section III-C). Moreover, some technologies for low-frequency bands (below 6 GHz) are also attracting attention such as massive MIMO with advanced space division multiplexing using massive antenna elements and high-spectrum-efficiency modulation technologies (e.g. higher-order modulation).

B) Technologies for accommodation of massive traffic

In order to accommodate 5G services, using wider spectrum is essential. Not only exploitation of frequency bands above 6 GHz but also spectrum refarming of existing mobile bands (below 6 GHz) is needed [10]. Though high-density deployment of small cells greatly contributes to accommodating massive traffic, an increase of inter-cell interference reduces the improvement of throughput,

especially in cell-edge areas. Therefore, technologies to mitigate inter-cell interference such as coordinated transmission between cells are important [11]. Moreover, offloading traffic to other systems (e.g. wireless local area network (WLAN)) and a cognitive radio that detects and utilizes unused frequency bands are effective to increase network capacity. LTE-Unclicensed is another important technology that can exploit unlicensed bands for mobile users. License-assisted access (LAA) discussed in 3GPP Release 13 is a typical realization of LTE-unclicensed where licensed bands and unlicensed bands are aggregated in order to offload mobile traffic on unlicensed bands while controlling mobility and quality of service. Listen before talk mechanism is used in LAA to avoid interference to existing WLAN systems. Although regulatory requirements for LAA can be found in [12], further discussion is continuing in 3GPP. To improve spectrum efficiency, there are technologies that eliminate interference at the receiver-side using the processing power of terminals such as non-orthogonal multiple access (NOMA) [13] and full duplex communication [14].

C) Technologies for accommodation of ultra-high-density devices

In order to accommodate massive devices in single cell, a simple signaling procedure is desired to reduce signaling overhead. Contention-based uplink access is one of the solutions to address the problem. Device-to-device (D2D) communication can also reduce the amount of signaling between massive devices and network. The traffic in/from large sensor networks that are the basis of the IOE is not very large or sensitive to latency. On the other hand, low-cost and low-power consumption are strongly required. Several new waveforms such as generalized frequency division multiplexing (GFDM) [15] and universal frequency multi-carrier [16] are proposed in order to simplify an idle procedure

and a synchronization procedure between terminals. These new waveforms have advantages of having a lower adjacent channel leakage power ratio and a lower peak to average power ratio than OFDM. An air interface also needs to be developed that can effectively accommodate massive control signals.

D) Technologies for low-latency and high-reliability communications

Low-latency communication can be realized by reduction of symbol length with new air interfaces such as filter bank multicarrier [17] that can reduce overhead of guard intervals. Network optimizations [18], such as deployment of processors and caches at base stations and selection of optimal network paths, are also effective to reduce latency. Mobile edge computing (MEC) is a promising platform to realize this architecture. For the MEC platform, enhanced security and protected privacy are also important [19]. In terms of the increase of reliability, communications in a very low signal to noise ratio (SNR) environment and data distributed caches are effective [20]. Moreover, the study of Isolated E-UTRAN Operation for Public Safety has been started in 3GPP [21], which can ensure the mission-critical communication even if base stations lose backhaul during or after a disaster. For low-latency and high reliability communications, special air-interfaces adjusted to special use cases could be needed. Therefore, dedicated frequency resources isolated from other services might be allocated statically and/or dynamically.

III. IMPORTANT DIRECTIONS FOR RESEARCH AND DEVELOPMENT OF 5G

As seen in Section II, it can be said that 5G is a heterogeneous network where various wireless access technologies (RAT), which can accommodate various services, are integrated. It should be difficult for conventional radio control schemes to control such various RATs efficiently. Therefore, we need a new kind of radio control method that can virtualize wireless networks and can use optimal RATs for each specific service based on the concept of a Software Defined Network.

Moreover, the need to make all human activities sustainable has increased due to rapid global warming and resource depletion concerns in recent years. While the future wireless network should be one of the tools to achieve such a sustainable society, it should aim to be sustainable in itself. The power consumption of mobile base stations and mobile backhuls is 60 TWh/year, which accounts for 11% of the electric power consumed in the ICT field, and it will increase by about 16–20% a year in the future [22]. Therefore, energy-saving of wireless networks is an important issue for avoiding imposing a large load on society as the services using mobile communications expand. In addition, it is also necessary to aim at reducing the bit cost for continuous development of such services.

Therefore, we propose two key directions for the research on 5G wireless networks: one is the achievement of a controller of a heterogeneous network that can accommodate various services efficiently, and the other is the achievement of a sustainable wireless network that requires operation and investment cost and energy consumption the same as or lower than existing wireless systems. Some of our studies related to 5G aiming at these directions are introduced in the following sub-sections.

A) Super-high-density cell control

The mobile traffic will increase rapidly with the increase of the number of new types of devices such as wearable and embedded devices in addition to the increase of the number of tablets and smart phones. A super-high-density cell deployment with C/U split technology is promising for accommodating such high-density traffic. However, capacity cannot increase linearly to the cell density because of high inter-cell interferences.

Therefore, we focus on the research on “dynamic virtual cell control” that adaptively changes the cell coverages according to the change of the user terminal distribution (http://jad.fujitsu.com/exhibit/ceatec/pdf/id_13.pdf). Dynamic virtual cell control can mitigate inter-cell interference and increase user throughput by controlling transmission power and transmission beam adaptively. Figure 4 shows an example of configuration for the dynamic virtual cell control where a centralized controller controls many distributed antennas.

Figure 5 shows an example of simulation results of the relationship between area capacity and cell density. The results suggest that an increase of cell densification alone cannot increase area throughput effectively because of the increase of inter-cell interference due to the increase of line-of-sight propagation environments. The results also suggest that significant improvement of throughput is possibly obtained by using beamforming and/or inter-cell coordination. Moreover, cell densification and inter-cell coordination also contribute to reducing energy consumption

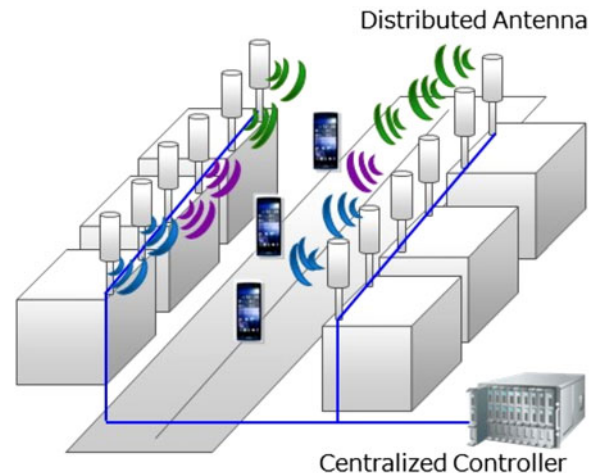

Fig. 4. Configuration for dynamic virtual cell control.

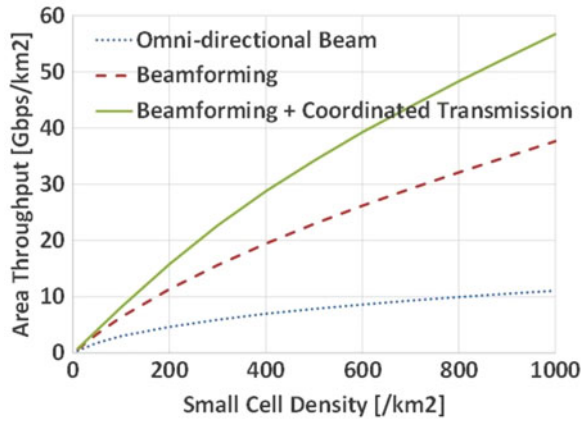

Fig. 5. Example of simulation results for cell densification.

because of reduction of transmission power and stoppage of signal transmissions.

B) LTE–WiFi interworking

As a realization of multi-RAT interworking, an LTE and WLAN interwork has attracted attention. Since cellular systems and WLAN are based on different architectures, a coordinated control in higher layers is necessary to realize seamless interwork between them. 3GPP has standardized a specification of interworking with WLAN that enables evolved packet core (EPC) to select a path to WLAN in order to offload traffic from a cellular network to public WLANs [23]. For LTE–WiFi interworking using public WLAN, automatic authentication is important to support service continuity. Hotspot 2.0 developed by WiFi Alliance is one of the technologies that provides seamless connectivity to public WLAN (<http://www.wi-fi.org/>). Using multipath TCP (MPTCP) standardized in IETF, more flexible cooperation of LTE and WLAN can be realized because multiple paths can be used at the same time, which results in the increase of throughput [24]. We proposed a new method that introduces an MPTCP proxy on a PDN gateway that accommodates LTE and WLAN [25]. We also proposed a path control architecture and a data relay architecture that satisfy three requirements: application transparency, protection of the existing communication function, and no prior settings of MPTCP proxy in user terminals. We equipped a Linux PC with the proposed architecture and evaluated its throughput and CPU utilization rate, which demonstrated that the proposed architecture is practical and useful (Fig. 6).

C) Low-energy consumption millimeter-wave communications

The most important feature of millimeter-wave communications is availability of a very wide bandwidth for communications, which enables very high-throughput communications. A massive beamforming with many antenna elements is promising to compensate for large

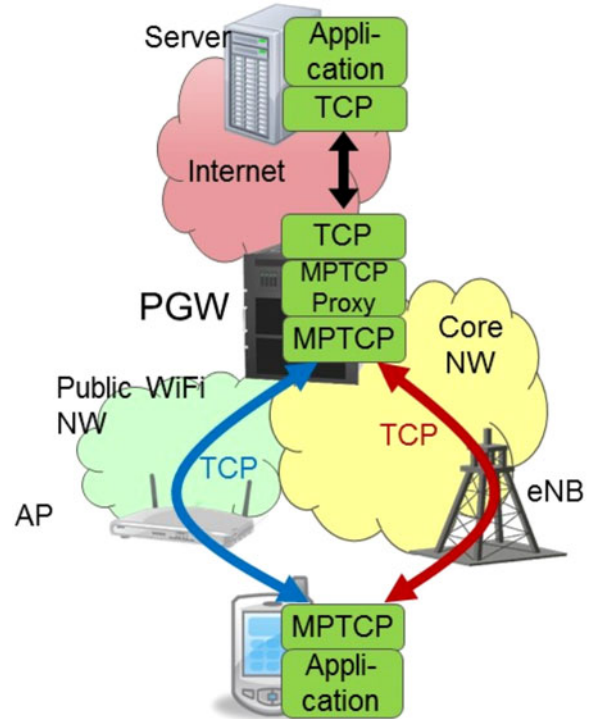

Fig. 6. MPTCP proxy relay architecture.

propagation loss of millimeter waves. Digital beamforming can realize flexible beamforming by being equipped with as many digital-to-analog converters (DAC) and RF chains as antenna elements (Fig. 7(a)). However, many DAC and RF chains result in large energy consumption.

Therefore, we are working on the development of a massive beamforming method that can give high throughput with a small number of DAC and RF chains. We proposed a new analog beamforming method for frequency-multiplexed users where only a single DAC and a single RF chain are used [26]. Since analog beamforming can only make one beam over the whole frequency, it is difficult to maintain beamforming gains for all of the frequency-multiplexed users. However, the proposed method makes a beam with multiple peaks that can be directed to multiple users (Fig. 7(b)). We demonstrated that the proposed analog beamforming method with two peaks with 64 antenna elements can increase user throughput by 45% more than the conventional single-peak analog beamforming method with the same number of antenna elements.

D) Green wireless networks with solar panels

Cooperating with the electric power network, 5G wireless is expected to improve energy efficiency. For example, distributed deployment of solar panels and batteries close to remote radio heads (RRH) will make the 5G wireless network energy efficient by reducing transmission loss, environmentally friendly due to zero CO₂ emission, and disaster resistant. For example, a solar panel of 0.2 m² can

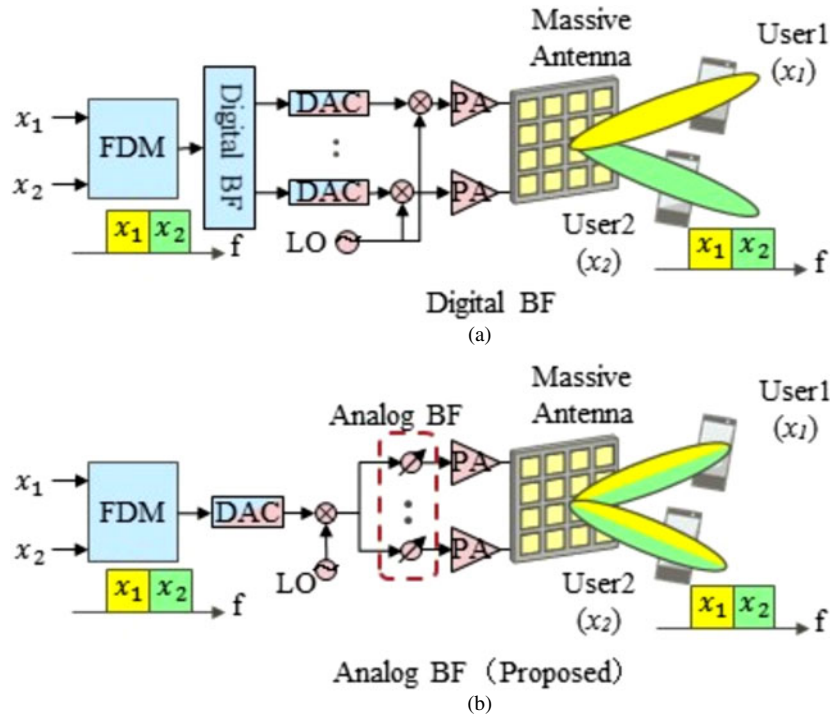

Fig. 7. Beamforming methods of millimeter-wave communications.

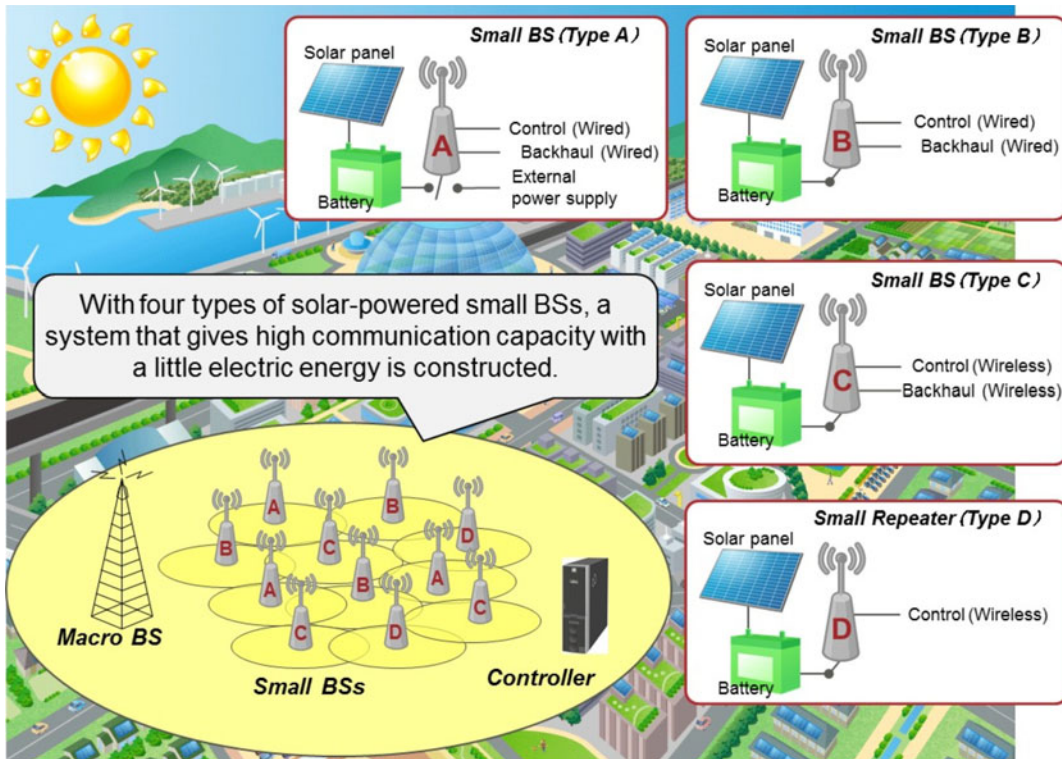

Fig. 8. Green wireless networks.

supply sufficient power to run a RRH of 8 W power consumption for 8 h/day [27]. On the other hand, a stable system operation is difficult since solar energy is unstable due to weather conditions. Therefore, we investigate a

system that contains different types of access points and controls transmission power of each access point considering remaining battery power, electric generating capacity, and data traffic (Fig. 8).

IV. CONCLUDING REMARKS

This paper described trends of the 5G wireless network, proposed important directions of the future research on 5G, and introduced some of our studies related to 5G. We proposed two key directions for the research on 5G wireless networks: one is the achievement of a controller of a heterogeneous network that can accommodate various services efficiently, and the other is the achievement of a sustainable wireless network that requires operation and investment cost and energy consumption the same as or lower than existing wireless systems.

The vision, candidate techniques, required performance, and other aspects of 5G have been actively investigated in many research projects. Based on the research results so far, people in this field are reaching a rough agreement about the vision, candidate techniques, and requirements of 5G. In the coming years, the research and development aiming at early realization of 5G systems will be accelerated.

We continue to advance the 5G research aiming at the realization of a hyper connected world in coordination with other researchers.

ACKNOWLEDGEMENTS

We thank the reviewers for comments that greatly improved the manuscript. We also appreciate the advices and materials given by other researchers of Network Systems Laboratory in Fujitsu Laboratories.

REFERENCES

- [1] Cisco: Global mobile data traffic forecast update, 2014–2019 White Paper, February 2015.
- [2] Cisco: The Internet of things how the next evolution of the Internet is changing everything, White Paper, April 2011.
- [3] Fettweis, G.P.: 5G – What will it be: the tactile internet, in *IEEE Int. Conf. on Communications (ICC2013)*, June 2013. Available: http://icc2013.ieee-icc.org/speakers_17_198889650.pdf
- [4] Rappaport, T.; Ben-Dor, E.; Murdock, J.; Qiao, Y.: 38 GHz and 60 GHz angle-dependent propagation for cellular amp; peer-to-peer wireless communications, in *Proc. IEEE Int Conf. on Communication (ICC)*, June 2012, 4568–4573.
- [5] ARIB 2020 and Beyond Ad Hoc Group: Mobile communications systems for 2020 and beyond White Paper, October 2014.
- [6] ITU-R Working Party 5D: Draft new Recommendation ITU-R M. [IMT-Vision] Framework and overall objectives of the future development of IMT for 2020 and beyond.
- [7] ITU-R Working Party 5D: Draft new Report ITU-R M. [IMT. FUTURE TECHNOLOGY TRENDS] Future technology trends of terrestrial IMT systems.
- [8] WEF: Risk and responsibility in a hyperconnected world, January 2014. Available: http://www3.weforum.org/docs/WEF_RiskResponsibility_HyperconnectedWorld_Report_2014.pdf
- [9] Swindlehurst, A.L. *et al.*: Millimeter-wave massive MIMO: the next wireless revolution? *IEEE Commun. Mag.*, 52 (9) (2014), 56–62.
- [10] GSMA: 5G spectrum policy position. Available: <http://www.gsma.com/spectrum/5g-spectrum-policy-position/>
- [11] Bhushan, N. *et al.*: Network densification: the dominant theme for wireless evolution into 5G. *IEEE Commun. Mag.*, 52 (2) (2014), 82–89.
- [12] 3GPP TR 36.889 V13.0.0: Study on licensed-assisted access to unlicensed spectrum, June 2015.
- [13] Saito, Y. *et al.*: Non-orthogonal multiple access (NOMA) for cellular future radio access, in *IEEE VTC Spring*, June 2013, 2–5.
- [14] Hong, S. *et al.*: Applications of self-interference cancellation in 5G and beyond. *IEEE Commun. Mag.*, 52 (2) (2014), 114–121.
- [15] Fettweis, G. *et al.*: GFDM – generalized frequency division multiplexing, in *VTC Spring 2009*, April 2009, 1–4.
- [16] Vakilian, V. *et al.*: Universal-filtered multi-carrier technique for wireless systems beyond LTE, in *Globecom 2013 Workshops*, December 2013, 9–13.
- [17] Farhang-Boroujeny, B.: OFDM versus filter bank multicarrier. *IEEE Signal Process. Mag.*, 28 (3) (2011), 92–112.
- [18] Wang, X. *et al.*: Cache in the air: exploiting content caching and delivery techniques for 5G systems, in *IEEE Communication Magazine*, February 2014, 52(2), 131–139.
- [19] ETSI: Mobile-edge computing – introductory technical white paper. Available: http://portal.etsi.org/Portals/o/TBpages/MEC/Docs/Mobile-edge_Computing_-_Introductory_Technical_White_Paper_V1%2018-09-14.pdf
- [20] Seppala, J. *et al.*: Network controlled Device-to-Device (D2D) and cluster multicast concept for LTE and LTE-A networks, in *IEEE WCNC 2011*, March 2011, 986–991.
- [21] 3GPP TR22.897 V13.0.0: Technical Specification Group Services and System Aspects; Study on Isolated Evolved Universal Terrestrial Radio Access Network (E-UTRAN) Operation for Public Safety, June 2014.
- [22] Tafazolli, R.; Mattila, V. *et al.*: eMobility Mobile and wireless communications technology platform: strategic research agenda, 2010. Available: <http://www.emobility.eu.org>
- [23] 3GPP TS23.402 V12.6.0: Architecture enhancements for non-3GPP accesses (Release 12), September 2014.
- [24] Ford, A. *et al.*: TPC extensions for multipath operation with multiple addresses, IETF RFC6824, January 2013.
- [25] Kojima, Y.; Kawasaki, T.; Suga, J.; Takechi, R.: An introduction method of multipath TCP to mobile core networks and its evaluations, IEICE technical report, NS2014-146, November 2014 (written in Japanese).
- [26] Fujio, S.; Koike, C.; Kimura, D.: A study on FDM method with analog beam-forming for millimeter-wave communications, in *Proc. IEICE Society Conf. 2014*, B-5-96, September 2014, 367 (written in Japanese).
- [27] Fujio, S.; Kimura, D.: Energy saving effect of solar powered repeaters for cellular mobile systems, in *Proc. IEEE Int. Symp. Personal Indoor and Mobile Radio Communication (PIMRC)*, September 2013, 2841–2845.

Dai Kimura received his B.E. and M.E. degrees in Mechanical Engineering from the University of Tokyo in 1996 and 1998, respectively. He joined Fujitsu Laboratories Ltd., Kanagawa, Japan in 1998. He was a visiting industrial fellow at ENST Bretagne (currently Telecom Bretagne) in France. He is currently a research manager at Network Systems Laboratory of

Fujitsu Laboratories Ltd. He has been engaged in the research and development of LTE and LTE-advanced systems. He is now engaged in a study on future wireless network systems. He is a member of IEEE and IEICE.

Hiroyuki Seki received his M.E. degree in Electrical Engineering from Tokyo Institute of Technology in 1992 and his Ph.D. degree in Information Science from Tohoku University, Sendai, Japan in 2015. He joined Fujitsu Laboratories Ltd., Kanagawa, Japan in 1992, where he has been engaged in research and development of radio access technologies for mobile communication systems. From 1999 to 2000, he was a visiting scholar at Stanford University where he studied smart antenna technologies. He is currently a research manager at Network Systems Laboratory of Fujitsu Laboratories Ltd. His current research interests include 5G mobile access technologies. He is a co-recipient of the Best Paper Award of the 76th IEEE Vehicular Technology Conference. He is a senior member of IEICE and IEEE.

Tokuro Kubo received the M.E. degree in Electrical Engineering from the Nagaoka University of Technology, Nagaoka, Japan in 1987. He joined Fujitsu Laboratories Ltd., Kanagawa, Japan in 1987, where he has been engaged in research and development of terrestrial radio communication systems and mobile communication systems, including the PDC system

and W-CDMA system. From 2006 to 2010, he was with Fujitsu R&D Center, Ltd, Beijing, China, working on mobile WiMAX, TD-LTE, and Optical coherent system. He now holds a research manager at Wireless Signal Processing Laboratory of Network Systems Laboratory. His main research interests are 5G mobile access technologies. He is a member of the Institute of Electronics, Information, and Communication Engineers (IEICE) of Japan.

Tomohiko Taniguchi received his B.S. degree in Electrical Engineering from the University of Tokyo in 1982, and joined Fujitsu Laboratories (Ph.D. degree in Information Science from the University of Tokyo, 2006). He was a visiting scholar at Stanford University (1987–1988), and was with Fujitsu Laboratories of America, Sunnyvale, CA, USA (1996–2000). Currently he is with Fujitsu Laboratories Ltd., Kawasaki, Japan, as a Research Principal. He has been active in the field of signal processing for more than 30 years, served for international conferences/committees (13 times Symposium Chair in IEEE ICC/Globecom), and is recognized for his inventions (essential patents for international standards, such as ITU-T, MPEG, and 3GPP). He is a recipient of numerous awards for his papers, patents, and contributions to the academic society. He is now giving a lecture at Beijing University of Posts and Telecommunications (Distinguished Visiting Professor: 2013–2018), and at DuyTan University (Guest Professor: 2014–2017). Dr. Taniguchi is a Fellow of IEEE and IEICE.